

MATERIALS AND FINISHES:

HOUSING: ZINC ALLOY
 PLATED SEE TABLE
 CENTER CONTACT :BRASS
 PLATED GOLD
 INSULATOR :TEFLON
 OUTER CONTACT :BERYLLIUM COPPER
 PLATED GOLD
 FERRULE: BRASS
 PLATED SEE TABLE
 CAP :STAINLESS STEEL (FOR 73366-0010)
 PLATED GOLD
 CAP :BRASS (FOR 73366-0011/-0012)
 PLATED GOLD

NOTE:
 73366-0011'S FERRULE FOR GENERAL CUSTOMERS
 73366-0012'S FERRULE FOR CHEN CHUN REQUEST

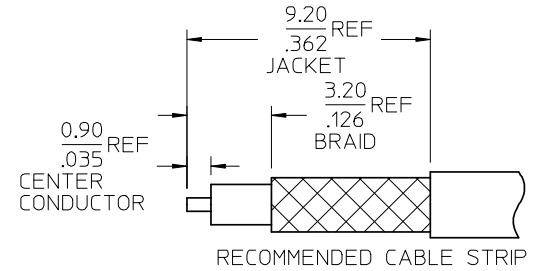
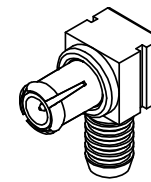
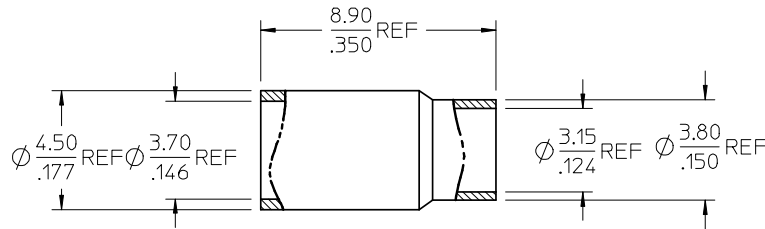
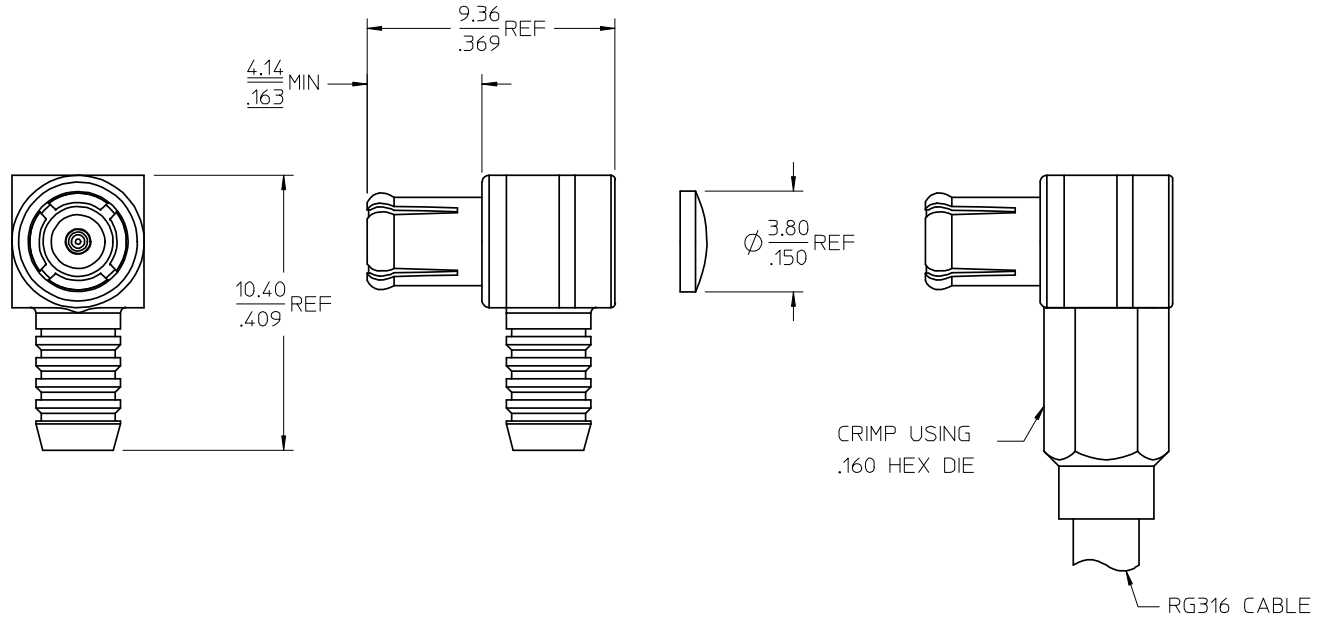

73366-0016	73366-0012 , SMALL TRAY
73366-0015	73366-0011 , SMALL TRAY
73366-0014	73366-0010 , SMALL TRAY
73366-0013	73366-0010 , ONE PER BAG
73366-0012	GOLD PLATING , BULK
73366-0011	GOLD PLATING , BULK
73366-0010	NICKEL PLATING , BULK
PART NO.	PLATING AND PACKAGING

PS-73598-0132	PRODUCT SPECIFICATIONS
AS-73392-005	CABLE ASSEMBLY INSTR.
SPECIFICATION	DESCRIPTION

CHG: UPDATED
 BODY VIEW.

EC NO: URF2008-0568
 DRW: IRIS WANG 2008/05/13
 CHK: DSS 2008/05/13
 APPR: JWIENER 2008/05/13

QUALITY SYMBOLS
 ▽=0
 ▽=0

GENERAL TOLERANCES (UNLESS SPECIFIED)

	mm	INCH
4 PLACES	± .005	± .0005
3 PLACES	± .003	± .0003
2 PLACES	± .002	± .0002
1 PLACE	± .001	± .0001

ANGULAR ± 2 °

DRAFT WHERE APPLICABLE MUST REMAIN WITHIN DIMENSIONS

DIMENSION STYLE: MM/IN

DRAWN BY: IRIS WANG DATE: 1997/05/13

CHECKED BY: BEER DATE: 2003/02/21

APPROVED BY: MISEN DATE: 2003/02/21

MATERIAL NO. SEE TABLE

SIZE: C

SCALE: DESIGN UNITS METRIC

THIRD ANGLE PROJECTION

TITLE: MCX PLUG, R/A FOR RG316 50 OHMS MCX-PC/RA

MOLEX INCORPORATED

DOCUMENT NO. SD-73366-001

SHEET NO. 1 OF 1

THIS DRAWING CONTAINS INFORMATION THAT IS PROPRIETARY TO MOLEX INCORPORATED AND SHOULD NOT BE USED WITHOUT WRITTEN PERMISSION